

ශ්‍රී ලංකා ප්‍රජාතාන්ත්‍රික සමාජවාදී ජනරජයේ ගැසට් පත්‍රය  
අති විශේෂ  
The Gazette of the Democratic Socialist Republic of Sri Lanka  
EXTRAORDINARY

අංක 1395/19 - 2005 ජූනි 02 වැනි බ්‍රහස්පතින්දා - 2005.06.02  
No. 1395/19 - THURSDAY, JUNE 02, 2005

(Published by Authority)

**PART I : SECTION (I) — GENERAL**

**Government Notifications**

L.D. — B 24/51(vii).

**MOTOR TRAFFIC ACT (CHAPTER 203)**

REGULATIONS made by the Minister of Transport under section 237 of the Motor Traffic (Chapter 203).

FELIX PERERA,  
Minister of Transport.

Colombo.  
01st June, 2005

**Regulation**

The Motor Traffic (Miscellaneous) regulations 1951, published in *Gazette Extraordinary* No. 10360 of February, 27, 1952 as amended from time to time is hereby further amended as follows :-

(1) by repeal of paragraph (a) of regulations 12 thereof, and the substitution therefore of the following :-

(a) a vehicle registration identification number plate sticker (hereinafter in this regulation referred to as “the sticker”) and more fully described in the Third Schedule to these regulations shall be issued in respect of all vehicles other than the motor vehicles referred to in regulation 17 of these regulations, on the payment of such fees as are specified in the Fourth Schedule in relation to the identification number plates referred to in paragraph 1.” ;

(2) by repeal of regulation 17 there of, and the substitution therefore of the following :-

“17 .(a) the identification number plate for the motor vehicle issued under the authority of dealers license shall be white hot stamped or pressed on to a red retro reflective background rectangular plate and the letter, figures and numbers on the plate shall be indelibly inscribed upon and so attached to such surface. The plate shall be constructed of cast or pressed metal having raised letters and embossed figures in such manner that the numbers inscriber thereon cannot be easily detached therefrom.

- (b) the identification number plates shall contain—
  - (i) the emblem of the government of Sri Lanka embedded into the retro reflective high quality aluminum sheeting on the top left hand corner incorporated with security features ;
  - (ii) two provincial identification letters shall be embossed below the emblem of the government of Sri Lanka at the bottom left hand corner.
  - (iii) one letter , one figure, a dash and four figures ; and
  - (iv) the chromium based security hologram which is hot stamped to the identification number plate above the dash.
- (c) The letters, figures and numbers on each identification number plate shall in accordance with such specifications as are set out in the Second Schedule to these regulations and be of uniform size.
- (d) The letter referred in b (iii) of this paragraph shall be indicative of the district identification and the figure shall indicate the last figure of the year of issue, of the number plate.” ;

(3) by repeal of regulation 18 thereof, and the substitution therefore of the following :-

“18. (a) The Identification number plate shall be of retro reflective plate and the letter, figures and numbers on the plate shall be indelibly inscribed upon and so attached to such surface that the plate shall be constructed of cast or pressed metal having raised letters embossed figure and numbers which cannot be easily detached therefrom.

- (b) the identification numbers plates shall contain—
  - (i) the emblem of the government of Sri Lanka embedded into the retro reflective high quality aluminum sheeting on the top left hand corner incorporated with security features ;
  - (ii) two provincial identification letters shall be embossed below the emblem of the government of Sri Lanka at the bottom left hand corner ;
  - (iii) two letters, a dash and four figures ; and
  - (iv) the chromium based security hologram which is hot stamped to the identification number plate above the dash ;
  - (v) the fuel type identification letter shall be embossed below the dash as “D” for diesel vehicle. “P” for petrol vehicles and “E” for electrically powered vehicles.
- (c) The letters, figures and numbers on each identification number plate shall be in accordance with such specifications as are set out in the Second Schedule to these regulations and be of uniform size.” ;

(4) by repeal of regulations 19 thereof and the substitution therefore of the following :-

“19 (a) For the purpose of these regulations the identification letters for the nine provinces shall be as follows :-

1. Western Province	-	WP
2. Southern Province	-	SP
3. Eastern Province	-	EP
4. Northern Province	-	NP
5. North Central Province	-	NC
6. Central Province	-	CP
7. North Western Province	-	NW
8. Sabaragamuwa Province	-	SG
9. Uva Province	-	UP

(b) For the purpose of these regulations the identification letters for the twenty five Administrative Districts shall be as follows :-

- |                  |   |          |
|------------------|---|----------|
| 1. Colombo       | - | C        |
| 2. Gampaha       | - | G        |
| 3. Kalutara      | - | K        |
| 4. Gale          | - | G        |
| 5. Matara        | - | M        |
| 6. Hambantota    | - | H        |
| 7. Ampara        | - | A        |
| 8. Batticloa     | - | B        |
| 9. Trincomalee   | - | T        |
| 10. Jaffna       | - | J        |
| 11. Kilinochchi  | - | K        |
| 12. Mulative     | - | U        |
| 13. Manner       | - | M        |
| 14. Vovniya      | - | V        |
| 15. Anuradhapura | - | A        |
| 16. Polonnaruwa  | - | P        |
| 17. Kandy        | - | K        |
| 18. Matale       | - | M        |
| 19. Nuwara Eliya | - | N        |
| 20. Kurunegala   | - | K        |
| 21. Puttlam      | - | P        |
| 22. Badulla      | - | B        |
| 23. Mornaragala  | - | M        |
| 24. Rathnapura   | - | R        |
| 25. Kegalle      | - | K.”; and |

(c) by substitution for the First Schedule and the Second Schedule thereof, of the following Schedules :-

FIRST SCHEDULE

The identification number plate on all motor vehicles shall be of the following dimensions.

Category of Vehicles	Size of Plate	Diagram
1. All Vehicles except land - Vehicles and Motor Cycles	520x110mm	No. 1
2. - do -	280x200mm	No. 2
3. - do -	280x180mm	No. 3
4. Land Vehicles and Motor Cycles	240xz130mm	No. 4
5. Motor Cycles	300x80mm	No. 5
6. All Vehicles	520x110	No. 6
7. All Vehicles	280x200mm	No. 7

DIAGRAM-1

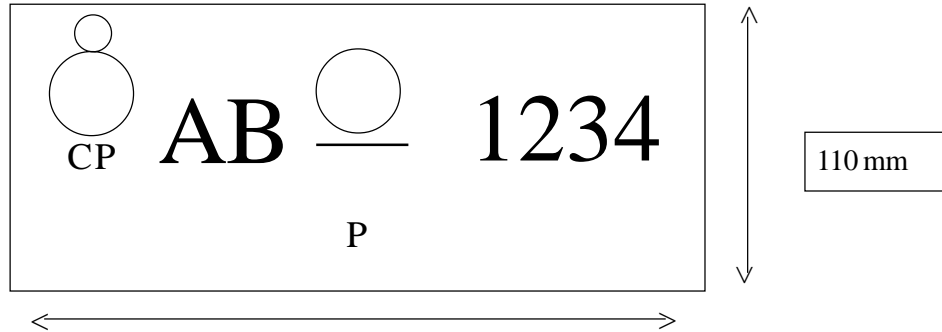

DIAGRAM-2

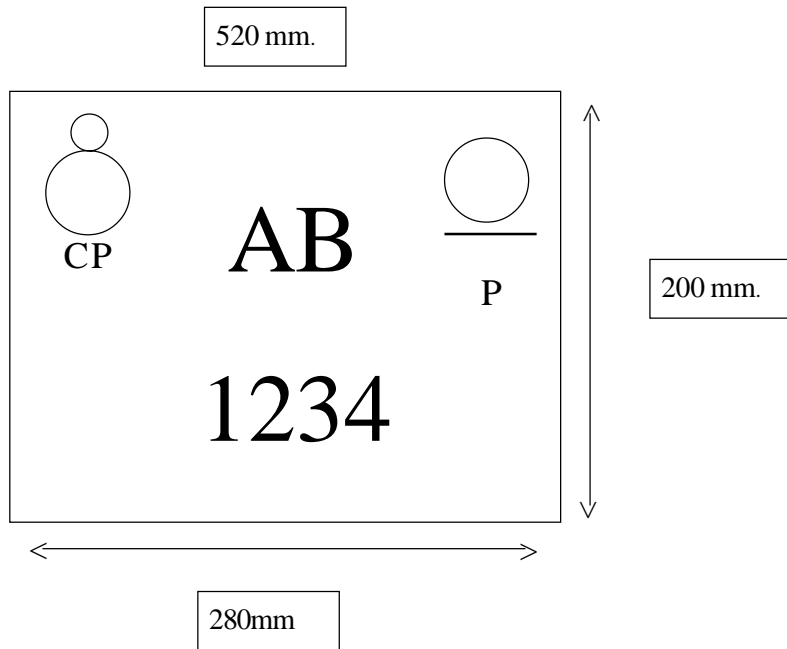

DIAGRAM-3

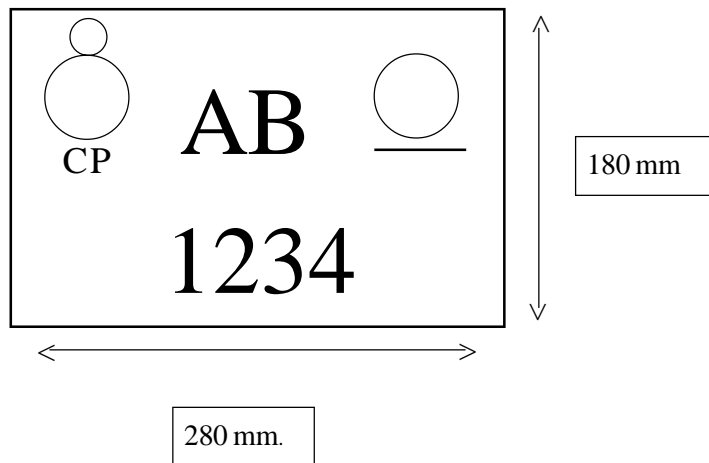

DIAGRAM-4

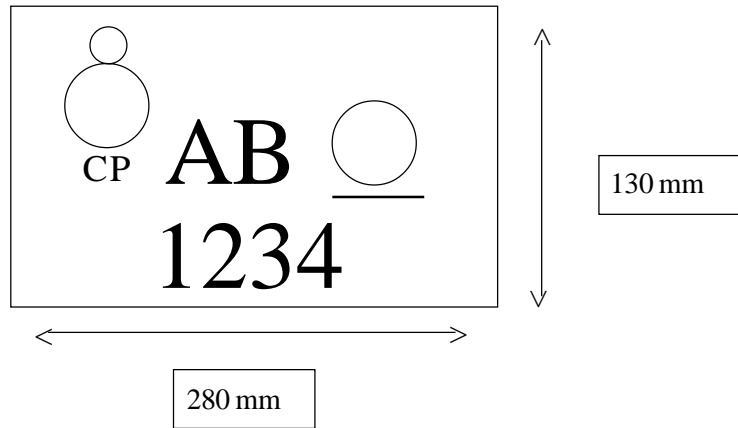

DIAGRAM-5

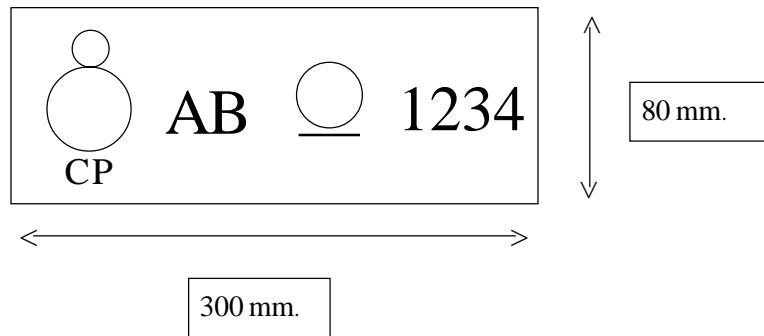

DIAGRAM-6

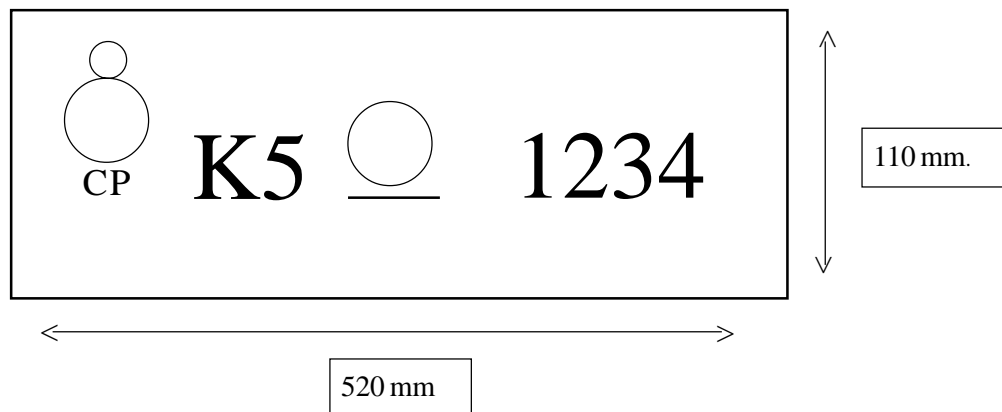
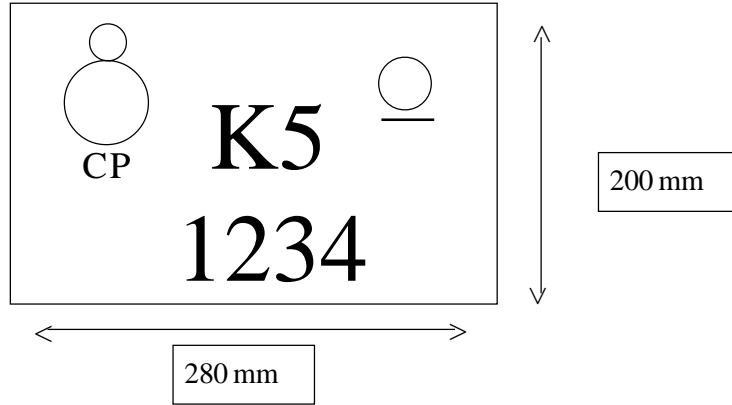

DIAGRAM-7



SECOND SCHEDULE

Category of Vehicles	Space between upper margin and - (in mm)				Space between upper margin and - (in mm)			
	Emblem	Letters	Security Mark	Numbers	Provincial Letters	Letters	Fuel type Identification no or dash	Numbers
1. All Vehicles	8	12	15	12	12	12	12	12
2. All Vehicles	8	12	15	-	86	-	-	12
3. All Vehicles	5	10	15	-	86	-	-	5
4. Land Vehicles and Motor Cycles	8	5	5	-	40	-	-	5
5. Motor Cycles	2	10	8	10	10	10	30	10
6. Dealer's License Plate for all Vehicles	8	12	15	12	12	12	45	12
7. Dealer's License Plate for all Vehicles	8	12	15	12	86	-	-	12

Category of Vehicles	Space between left margin (in mm)			Space between Right margin (in mm)				Space between two rows (in mm)			
	Emblem	Prov. Letters	Numbers	Security Mark	Dash	Num.	Fuel type identification	Prov. Letters	Letters	Dash	Dash
1. All Vehicles	28	12	-	-	-	10	-	-	-	-	-
2. All Vehicles	28	10	35	28	13	35	28	15	15	9	14
3. All Vehicles	28	10	35	33	23	35	33	15	15	8	10
4. Land Vehicles and Motor Cycles	25	10	70	20	-	20	-	-	15	-	-
5. Motor Cycles	20	6	-	-	-	6	-	-	-	-	-
6. Dealer's License Plate for All Vehicles	28	12	-	-	-	10	-	-	-	-	-
7. Dealer's License Plate for all Vehicles	28	10	35	28	13	35	28	15	15	9	14

Category of Vehicles	Emblem (in-mm)	Provincial Identification Letters (In-mm)	Security Stamp Diameter (in-mm)	Dash (In-mm)	Height, Width and Thickness of letters(in mm)	Height, Width and Thickness of numbers (in-mm)	Height, Width and Thickness Fuel type identification number in mm
1. All Vehicles	35x25	40x20x6	20	45x9	75x47.5x12	75x45x12	25x158x4
2. All Vehicles	35x25	40x20x6	20	45x9	75x47.5x12	75x45x12	25x158x4
3. All Vehicles	35x25	40x20x6	20	38x7	75x47.5x12	75x45x12	25x158x4
4. Land Vehicles and Motor Cycles	30x20	35x18x5	20	30x7	50x30x7	50x25x7	-
5. Motor Cycles	25x17	28x15x5	20	25x7	49x26.5x8	49x25x8	-
6. Dealer's License Plate for all Vehicles	35x25	40x20x6	20	45x9	75x47.5x12	75x45x12	-
7. Dealer's License Plate for all Vehicles	35x25	40x20x6	20	45x	75x47.5x12	75x45x12	-

Category of Vehicles	Space between Provincial Letters(in-mm)	Space between numbers (in-mm)	Space between emblem and Provincial Identification (in-mm)	Space between security stamp and the dash (in-mm)	Space between the dash and the numbers/or fuel identification letter in mm
1. All Vehicles	17	10	5	15	33
2. All Vehicles	17	10	5	15	9
3. All Vehicles	17	10	5	13	8
4. Land Vehicles and Motor Cycles	12	8	5	8	22
5. Motor Cycles	12	8	5	6	20
6. Dealer's License Plate for all Vehicles	17	10	5	15	33
7. Dealer's License Plate for all Vehicles	17	10	5	15	9